

ETA-Danmark A/S  
Kollegievej 6  
DK-2920 Charlottenlund  
Tel. +45 72 24 59 00  
Fax +45 72 24 59 04  
Internet www.etadanmark.dk



MEMBER OF EOTA

Authorised and notified according to Article 10 of the Council Directive 89/106/EEC of 21 December 1988 on the approximation of laws, regulations and administrative provisions of Member States relating to construction products

## European Technical Approval ETA-08/0053

Trade name:	Simpson Strong-Tie skewed joist hangers type S45, S1530, SUR/L, HSUR/L				
Holder of approval:	Simpson Strong-Tie Z.A.C. des Quatre Chemins F-85400 Sainte Gemme La Plaine France Tel. +33 2 51 28 44 00 Fax +33 2 51 28 44 01 Internet www.simpson.fr				
Generic type and use of construction product:	Three-dimensional nailing plate (joist hanger for wood to wood connections and wood to concrete)				
Valid from:	2008-03-27				
to:	2013-03-27				
Manufacturing plant:	<table><tr><td>Simpson Strong-Tie A/S</td><td>Simpson Strong-Tie ZAC des Quatre Chemins 4-11, Boulstrup 8300 Odder Denmark</td><td>Simpson Strong-Tie ZAC des Quatre Chemins 85400 Sainte Gemme La Plaine France</td><td>Simpson Strong-Tie Winchester Road Cardinal Point Tamworth Staffordshire B78 3HG United Kingdom</td></tr></table>	Simpson Strong-Tie A/S	Simpson Strong-Tie ZAC des Quatre Chemins 4-11, Boulstrup 8300 Odder Denmark	Simpson Strong-Tie ZAC des Quatre Chemins 85400 Sainte Gemme La Plaine France	Simpson Strong-Tie Winchester Road Cardinal Point Tamworth Staffordshire B78 3HG United Kingdom
Simpson Strong-Tie A/S	Simpson Strong-Tie ZAC des Quatre Chemins 4-11, Boulstrup 8300 Odder Denmark	Simpson Strong-Tie ZAC des Quatre Chemins 85400 Sainte Gemme La Plaine France	Simpson Strong-Tie Winchester Road Cardinal Point Tamworth Staffordshire B78 3HG United Kingdom		

This European Technical Approval contains: 24 pages including 2 annexes which form an integral part of the document



European Organisation for Technical Approvals

Europæisk Organisation for Tekniske Godkendelser

## I LEGAL BASIS AND GENERAL CONDITIONS

1. This European Technical Approval is issued by ETA-Danmark A/S in accordance with:
  - Council Directive 89/106/EEC of 21 December 1988 on the approximation of laws, regulations and administrative provisions of Member States relating to construction products<sup>1)</sup>, as amended by Council Directive 93/68/EEC of 22 July 1993<sup>2)</sup>.
  - Bekendtgørelse 559 af 27-06-1994 (afløser bekendtgørelse 480 af 25-06-1991) om ikrafttræden af EF direktiv af 21. december 1988 om indbyrdes tilnærmelse af medlemsstaternes love og administrative bestemmelser om byggevarer.
  - Common Procedural Rules for Requesting, Preparing and the Granting of European Technical Approvals set out in the Annex to Commission Decision 94/23/EC<sup>3)</sup>.
  - EOTA Guideline ETAG 015 *Three-dimensional nailing plates*, September 2002 edition.
2. ETA-Danmark A/S is authorized to check whether the provisions of this European Technical Approval are met. Checking may take place in the manufacturing plant. Nevertheless, the responsibility for the conformity of the products to the European Technical Approval and for their fitness for the intended use remains with the holder of the European Technical Approval.
3. This European Technical Approval is not to be transferred to manufacturers or agents of manufacturers other than those indicated on page 1, or manufacturing plants other than those indicated on page 1 of this European Technical Approval.
4. This European Technical Approval may be withdrawn by ETA-Danmark A/S pursuant to Article 5(1) of Council Directive 89/106/EEC.
5. Reproduction of this European Technical Approval including transmission by electronic means shall be in full. However, partial reproduction can be made with the written consent of ETA-Danmark A/S. In this case partial reproduction has to be designated as such. Texts and drawings of advertising brochures shall not contradict or misuse the European Technical Approval.
6. This European Technical Approval is issued by ETA-Danmark A/S in English. This version corresponds fully to the version circulated within EOTA. Translations into other languages have to be designated as such.

1) Official Journal of the European Communities N° L40, 11 Feb 1989, p 12.  
2) Official Journal of the European Communities N° L220, 30 Aug 1993, p 1.  
3) Official Journal of the European Communities N° L 17, 20 Jan 1994, p 34.

## II SPECIAL CONDITIONS OF THE EUROPEAN TECHNICAL APPROVAL

### 1 Definition of product and intended use

#### Definition of the product

Simpson Strong-tie joist hangers type S45, S1530, SUL, SUR, HSUL, HSUR are one piece, non-welded, skewed joist hangers. They are intended for timber-to-timber, timber-to-concrete or timber-to-steel connections fastened by a range of nails, screws or bolts.

The joist hangers are made from pre-galvanized steel Grade S 250 GD + min. Z275 according to EN 10326:2004 and EN 10143: 1993, or Grade G90 galv. Steel SS Grade 33 to ASTM A653, Min. yield strength 227 MPa and Min. ultimate strength 310 MPa. Dimensions, hole positions and typical installations are shown in Annex A.

#### Intended use

The joist hangers are intended for use in making end-grain to side-grain connections in load bearing timber structures, as a connection between a wood based joist and a solid timber or wood based header, where requirements for mechanical resistance and stability and safety in use in the sense of the Essential Requirements 1 and 4 of Council Directive 89/106/EEC shall be fulfilled. They are also intended for use in making an end-grain connection between a timber joist and a concrete structure or a steel member.

The joist hangers can be installed as connections between wood based members such as:

- Solid timber classified to C14-C40 according to EN 338 / EN 14081.
- Glued members of timber classified to C14 – C40 according to EN338 / EN14081 when structural adhesives are used.
- Glued laminated timber classified to GL24-GL36 according to EN 1194 / EN 14080.
- Solid Wood Panels, SWP according to EN 13353.
- Laminated Veneer Lumber LVL according to EN 14374.
- Laminated Strand Lumber, e.g. Parallam and Timber Strand.
- Plywood according to EN 636
- I-beams with backer blocks on both side of the web in the header and web stiffeners in the joist.

However, the calculation methods are only allowed for a characteristic wood density of up to 350 kg/m<sup>3</sup>. Even though the wood based material may have a larger density, this must not be used in the formulas for the load-carrying capacities of the fasteners.

Annex B states the characteristic load-carrying capacities of the joist hanger connections.

The design of the connections shall be in accordance with Eurocode 5 or a similar national Timber Code.

It is assumed that the forces acting on the joist hanger connection are the following  $F_{up}$  and  $F_{down}$  as shown in the figure below. The forces  $F_{up}$  and  $F_{down}$  shall act in the middle of the joist hanger.

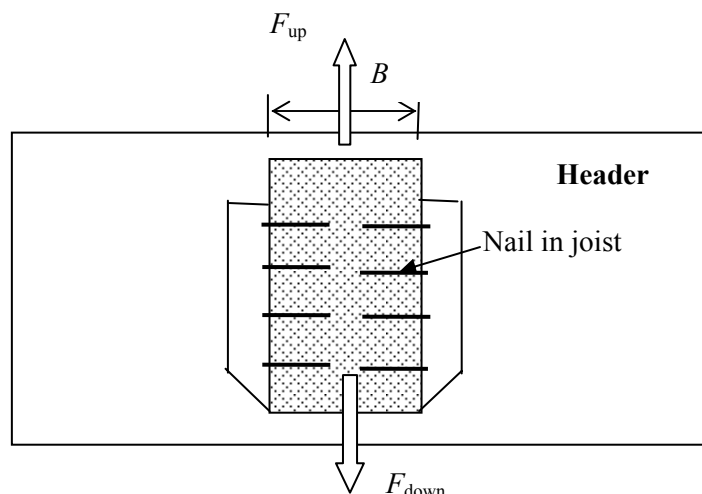

It is assumed that the header is prevented from rotating. Similar it is assumed that the concrete structure or the steel member to which the joist hanger is bolted does not rotate. If the header beam only has installed a joist hanger on one side the eccentricity moment  $M_v = F_d \cdot (B_H / 2 + 30mm)$  shall be considered. The same applies when the header has joist hanger connections on both sides, but with vertical forces which differ more than 20%.

The joist hangers are intended for use for connections subject to static or quasi static loading.

The zinc-coated hangers are for use in timber structures subject to dry, internal conditions defined by the service classes 1 and 2 of EN 1995-1-1:2004, (Eurocode 5).

For timber or wood based material with a lower characteristic density than 350 kg/m<sup>3</sup> the load-carrying capacities shall be reduced by the  $k_{dens}$  factor:

$$k_{dens} = \left( \frac{\rho_k}{350} \right)^2$$

Where  $\rho_k$  is the characteristic density of the timber in kg/m<sup>3</sup>.

For timber or wood based material with a higher characteristic density than 350 kg/m<sup>3</sup> the load-carrying capacities shall be taken as that for 350 kg/m<sup>3</sup>.

The wood members shall have a thickness which is larger than the penetration depth of the nails into the members.

**Assumed working life**

The assumed intended working life of the joist hangers for the intended use is 50 years, provided that they are subject to appropriate use and maintenance.

The information on the working life should not be regarded as a guarantee provided by the manufacturer or ETA-Danmark A/S. An “assumed intended working life” means that it is expected that, when this working life has elapsed, the real working life may be, in normal use conditions, considerably longer without major degradation affecting the essential requirements.

## 2 Characteristics of product and assessment

ETAG para.	Characteristic	Assessment of characteristic
<b>2.1</b>	<b>Mechanical resistance and stability*)</b>	
6.1.1	Characteristic load-carrying capacity	See Annex B
6.1.2	Stiffness	No performance determined
6.1.3	Ductility in cyclic testing	No performance determined
<b>2.2</b>	<b>Safety in case of fire</b>	
6.2.1	Reaction to fire	The angle brackets are made from steel classified as <b>Euroclass A1</b> in accordance with EN 13501-1 and EC decision 96/603/EC, amended by EC Decision 2000/605/EC
<b>2.3</b>	<b>Hygiene, health and the environment</b>	
6.3.1	Influence on air quality	No dangerous materials **)
<b>2.4</b>	<b>Safety in use</b>	Not relevant
<b>2.5</b>	<b>Protection against noise</b>	Not relevant
<b>2.6</b>	<b>Energy economy and heat retention</b>	Not relevant
<b>2.7</b>	<b>Related aspects of serviceability</b>	
6.7.1	Durability	The angle brackets have been assessed as having satisfactory durability and serviceability when used in timber structures using the timber species described in Eurocode 5 and subject to the dry internal or outdoor conditions defined by service class 1 and 2
6.7.2	Serviceability	
6.7.3	Identification	

\*) See page 8 of this ETA

\*\*\*) In accordance with <http://europa.eu.int/-/comm/enterprise/construction/internal/dangsub/dangmain.htm> In addition to the specific clauses relating to dangerous substances contained in this European Technical Approval, there may be other requirements applicable to the products falling within its scope (e.g. transposed European legislation and national laws, regulations and administrative provisions). In order to meet the provisions of the EU Construction Products Directive, these requirements need also to be complied with, when and where they apply.

### Safety principles and partial factors

The characteristic load-carrying capacities have been calculated considering different ratios between the partial factors for timber connections and steel cross sections.

According to clause 6.3.5 of EN 1990 (Eurocode – Basis of structural design) the characteristic resistance for structural members that comprise more than one material acting in association should be calculated as

$$R_d = \frac{1}{\gamma_{M,1}} R \left\{ \eta_1 X_{k,1}; \eta_i X_{k,i(i>1)} \frac{\gamma_{m,1}}{\gamma_{m,i}}; a_d \right\}$$

where  $\gamma_{M,1}$  is the global partial factor for material 1 (in this case wood),  $\gamma_{m,1}$  is the partial factor on the material 1 and  $\gamma_{m,i}$  are material partial factors for the other materials, i.e. the calculations are made with material parameters modified by multiplication by

$$k_{modi} = \gamma_{m,1} / \gamma_{m,i}$$

The characteristic load-carrying capacities have been calculated considering a ratio between the partial factor for timber connections and steel cross sections

$$k_{modi} = 1,18 \quad (EC5: k_{modi} = \frac{1,30}{1,10} = 1,18)$$

For  $k_{modi} > 1,18$  the load-carrying capacities stated in Annex B are valid (on the safe side).

For  $k_{modi} < 1,18$  the load-carrying capacities stated in Annex B have to be multiplied by a factor

$$k_{safe} = \frac{k_{modi}}{1,18}$$

## 2.1 Mechanical resistance and stability

See annex B for characteristic load-carrying capacity of the joist hanger connections.

The characteristic capacities of the joist hangers are determined by calculation assisted by testing as described in the EOTA Guideline 015 clause 5.1.2. They should be used for designs in accordance with Eurocode 5 or a similar national Timber Code.

Further, the joist hangers type S45 can be fastened to a concrete structure or steel member by anchor bolts with a diameter of 12 mm in holes with a diameter up to 2 mm larger than the bolt.

No performance has been determined in relation to ductility of a joint under cyclic testing. The contribution to the performance of structures in seismic zones, therefore, has not been assessed.

No performance has been determined in relation to the joint's stiffness properties - to be used for the analysis of the serviceability limit state.

*Connector nails and screws in accordance to ETA-04/0013*

In the formulas in Annex B the capacities for connector nails and connector screws in accordance to ETA-04/0013 are used.

*Square Twist nails in accordance to prEN 14592*

The capacities of square twist nails have been calculated from the formulas of Eurocode 5 assuming a thick steel plate when calculating the lateral nail load bearing capacity.

*Round smooth nails in accordance to prEN 14592*

The capacities of round smooth nails have been calculated from the formulas of Eurocode 5 assuming a thin steel plate when calculating the lateral load bearing capacity.

## 2.7 Related aspects of serviceability

*2.7.1 Corrosion protection in service class 1 and 2.*

In accordance with ETAG 015 shall the joist hangers have a zinc coating weight of min. Z275. The steel employed is S250 GD with min. Z275 according to EN 10326:2004, G90 SS Grade 33 according to ASTM A-653 and G185 SS Grade 33 according to ASTM A-653.

### **3 Attestation of Conformity and CE marking**

#### **3.1 Attestation of Conformity system**

The system of attestation of conformity is 2+ described in Council Directive 89/106/EEC (Construction Products Directive) Annex III.

- a) Tasks for the manufacturer:
  - (1) Factory production control,
  - (2) Initial type testing of the product,
- b) Tasks for the notified body:
  - (1) Initial inspection of the factory and the factory production control,
  - (2) Continuous surveillance

#### **3.2 Responsibilities**

##### *3.2.1 Tasks of the manufacturer*

###### *3.2.1.1 Factory production control*

The manufacturer has a factory production control system in the plant and exercises permanent internal control of production. All the elements, requirements and provisions adopted by the manufacturer are documented in a systematic manner in the form of written policies and procedures. This production control system ensures that the product is in conformity with the European Technical Approval.

The manufacturer shall only use raw materials supplied with the relevant inspection documents as laid down in the control plan<sup>1</sup>. The incoming raw materials shall be subject to controls and tests by the manufacturer before acceptance. Check of materials, such as sheet metal, shall include control of the inspection documents presented by suppliers (comparison with nominal values) by verifying dimension and determining material properties, e.g. chemical composition, mechanical properties and zinc coating thickness.

The manufactured components are checked visually and for dimensions.

The control plan, which is part of the technical documentation of this European Technical Approval, includes details of the extent, nature and frequency of testing and controls to be performed within the factory

---

<sup>1</sup> The control plan has been deposited at the ETA-Danmark A/S and is only made available to the approved bodies involved in the conformity attestation procedure.

production control and has been agreed between the approval holder and ETA-Danmark A/S.

The results of factory production control are recorded and evaluated. The records include at least the following information:

- Designation of the product, basic material and components;
- Type of control or testing;
- Date of manufacture of the product and date of testing of the product or basic material and components;
- Result of control and testing and, if appropriate, comparison with requirements;
- Signature of person responsible for factory production control.

The records shall be presented to ETA-Danmark A/S on request

##### *3.2.1.1 Initial type testing of the product*

For initial type testing the results of the tests performed as part of the assessment for the European Technical Approval shall be used unless there are changes in the production line or plant. In such cases the necessary initial type testing has to be agreed between ETA-Danmark A/S and the notified body

##### *3.2.2. Tasks of notified bodies*

###### *3.2.2.1 Initial inspection of the factory and the factory production control*

The approved body should ascertain that, in accordance with the control plan, the factory, in particular the staff and equipment, and the factory production control, are suitable to ensure a continuous and orderly manufacturing of the skewed joist hangers with the specifications given in part 2.

###### *3.2.2.2 Continuous surveillance*

The approved body shall visit the factory at least twice a year for routine inspections. It shall be verified that the system of factory production control and the specified manufacturing processes are maintained, taking account of the control plan.

The results of product certification and continuous surveillance shall be made available on demand by the certification body to ETA-Danmark A/S. Where the provisions of the European Technical Approval and the control plan are no longer fulfilled, the certificate of conformity shall be withdrawn by the approved body.

### **3.3 CE marking**

The CE marking shall be affixed on each packaging of the joist hangers. The initials "CE" shall be accompanied by the following information:

- Name or identifying mark of the manufacturer
- The last two digits of the year in which the marking was affixed
- Number of the EC certificate of conformity
- Number of the ETA Guideline (ETAG no. 015)
- Number of the European Technical Approval
- Name and size of product

## 4 Assumptions under which the fitness of the product for the intended use was favourably assessed

### 4.1 Manufacturing

The joist hangers are manufactured in accordance with the provisions of the European Technical Approval using the automated manufacturing process as identified during the inspection of the plant by ETA-Danmark A/S and the approved body and laid down in the technical documentation.

### 4.2 Installation

#### Joist hanger connections

A joist hanger connection is deemed fit for its intended use provided:

#### Header – support conditions

- The header shall be restrained against rotation and be free from wane under the joist hanger.
- If the header carries joists only on one side the eccentricity moment from the joists  $M_{ec} = R_{joist} (b_{header}/2 + e_{nail})$  shall be considered at the strength verification of the header.
 

$R_{joist}$	Reaction force from the joists
$b_{header}$	Width of header
$e_{nail}$	Distance from nails in the joist to the surface of the header
- For a header with joists from both sides but with different reaction forces a similar consideration applies.

#### Wood to wood connections

- Joist hangers can be fastened to wood-based members by nails or screws.
- There shall be nails or screws in all holes as prescribed in Annex B.
- The characteristic capacity of the joist hanger connection is calculated according to the manufacturer's technical documentation, dated 2007-10-17.
- The joist hanger connection is designed in accordance with Eurocode 5 or an appropriate national code.
- The gap between the end of the joist and the surface, where contact stresses can occur during loading shall be limited. This means that for joist hangers with outward flaps shall the gap between the surface of the end of the joist and that of the header be maximum 3 mm.

- Nail types and sizes shall be those mentioned in the tables of Annex B.
- The cross section of the joist at the joist hanger connection shall have sharp edges at the lower side against the bottom plate, i.e. it shall be without wane.
- The cross section of the header shall have a plane surface against the whole joist hanger.
- The width  $b_J$  of the joist shall correspond to that of the joist hanger.  $b_J$  shall not be smaller than  $B-3$  mm, where  $B$  is the inner width of the joist hanger.
- The depth of the joist shall be so large that the top of the joist is at least 20 mm above the upper nail in the joist.
- The end of the joist shall be cut perpendicular to its length direction

#### Wood to concrete or steel

The above mentioned rules for wood to wood connections are applicable also for the connection between the joist and the joist hanger.

- The joist hanger shall be in close contact with the concrete or steel over the whole face. There shall be no intermediate layers in between.
- The gap between the end of the joist and the surface, where contact stresses can occur during loading shall be limited. This means that the gap between the surface of the end of the joist and that of the concrete or steel shall be maximum 3 mm.
- The bolt shall have a diameter not less than the hole diameter minus 2 mm.
- The bolts shall be placed symmetrically about the vertical symmetry line. There shall always be 2 bolts in each side flange of the S45 hanger.
- The bolts shall have ordinary washers
- The end of the joist shall be cut perpendicular to its length direction

### 4.3 Maintenance and repair

Maintenance is not required during the assumed intended working life.

Should repair prove necessary, it is normal to replace the joist hanger.



Thomas Bruun  
Manager, ETA-Danmark

## Annex A Product details and definitions

### Products dimensions, holes and steel specifications

#### S45 hangers

S45 right skewed hanger:

Item	Dimensions (mm)						Hole Nail			Hole Bolt		Steel
	A	B	C	D	E	Thick	Nb header	Nb Joist (open side)	Nb Joist (closed side)	Nb header	Nb Joist	
S45D250/38/1,5	38	106	38	36	77,7	1,5	16 - $\emptyset 5$	8 - $\emptyset 5$	8 - $\emptyset 5$	2 - $\emptyset 11$	4 - $\emptyset 9$	S250GD + Z275
S45D320/38/2	38	141	70	40	100	2	18 - $\emptyset 5$	5 - $\emptyset 5$	5 - $\emptyset 5 \times 7,5$	4 - $\emptyset 13$	--	
S45D380/76/2	76	152	70	40	100	2	26 - $\emptyset 5$	6 - $\emptyset 5 + 1 \text{ opt}$	6 - $\emptyset 5 \times 7,5 + 1 \text{ opt}$	4 - $\emptyset 13$	--	
S45D440/80/2	80	180	70	40	100	2	28 - $\emptyset 5$	7 - $\emptyset 5 + 1 \text{ opt}$	7 - $\emptyset 5 \times 7,5 + 1 \text{ opt}$	4 - $\emptyset 13$	--	
S45D500/100/2	100	200	70	40	102	2	34 - $\emptyset 5$	9 - $\emptyset 5 + 1 \text{ opt}$	9 - $\emptyset 5 \times 7,5 + 1 \text{ opt}$	4 - $\emptyset 13$	--	

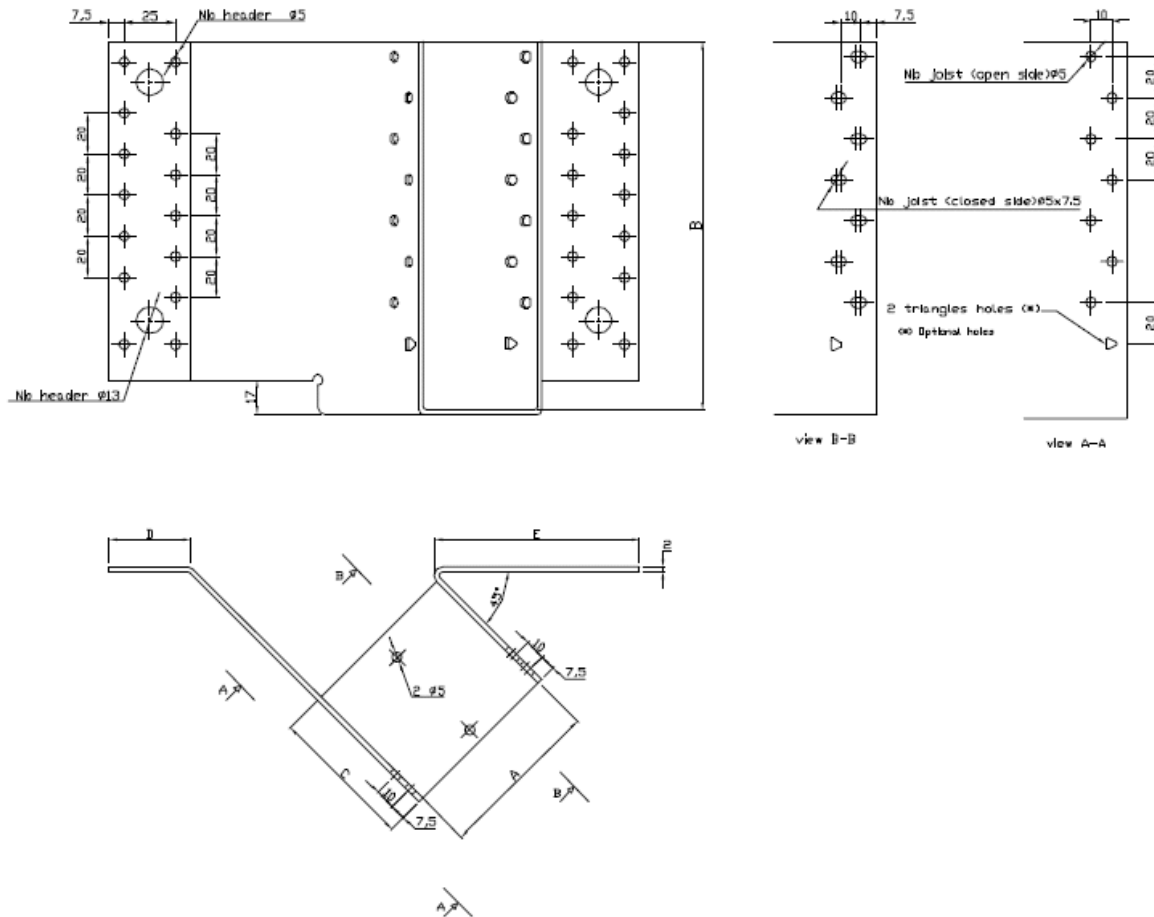

Figure 1: Dimensioned drawing of right skewed hangers S45

S45 left skewed hanger:

Item	Dimensions (mm)						Hole Nail			Hole Bolt		Steel
	A	B	C	D	E	Thick	Nb header	Nb Joist (open side)	Nb Joist (closed side)	Nb header	Nb Joist	
S45G250/38/1,5	38	106	38	36	77,7	1,5	16 - $\emptyset 5$	8 - $\emptyset 5$	8 - $\emptyset 5$	2 - $\emptyset 11$	4 - $\emptyset 9$	S250GD + Z275
S45G320/38/2	38	141	70	40	100	2	18 - $\emptyset 5$	5 - $\emptyset 5$	5 - $\emptyset 5 \times 7,5$	4 - $\emptyset 13$	--	
S45G380/76/2	76	152	70	40	100	2	26 - $\emptyset 5$	6 - $\emptyset 5 + 1 \text{ opt}$	6 - $\emptyset 5 \times 7,5 + 1 \text{ opt}$	4 - $\emptyset 13$	--	
S45G440/80/2	80	180	70	40	100	2	28 - $\emptyset 5$	7 - $\emptyset 5 + 1 \text{ opt}$	7 - $\emptyset 5 \times 7,5 + 1 \text{ opt}$	4 - $\emptyset 13$	--	
S45G500/100/2	100	200	70	40	102	2	34 - $\emptyset 5$	9 - $\emptyset 5 + 1 \text{ opt}$	9 - $\emptyset 5 \times 7,5 + 1 \text{ opt}$	4 - $\emptyset 13$	--	

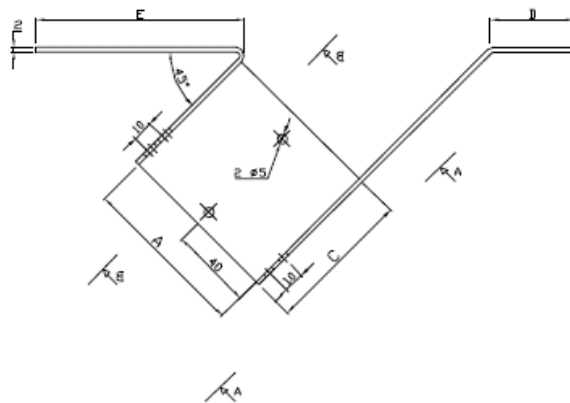
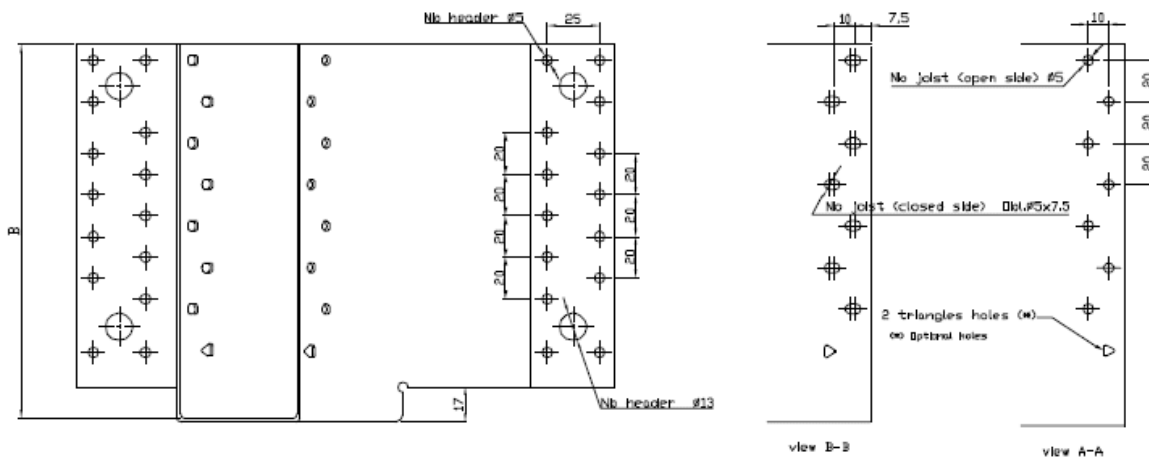

Figure 2: Dimensioned drawing of left skewed hangers S45

### S1530 hangers

S1530G/38/1.5

A (1 : 2)

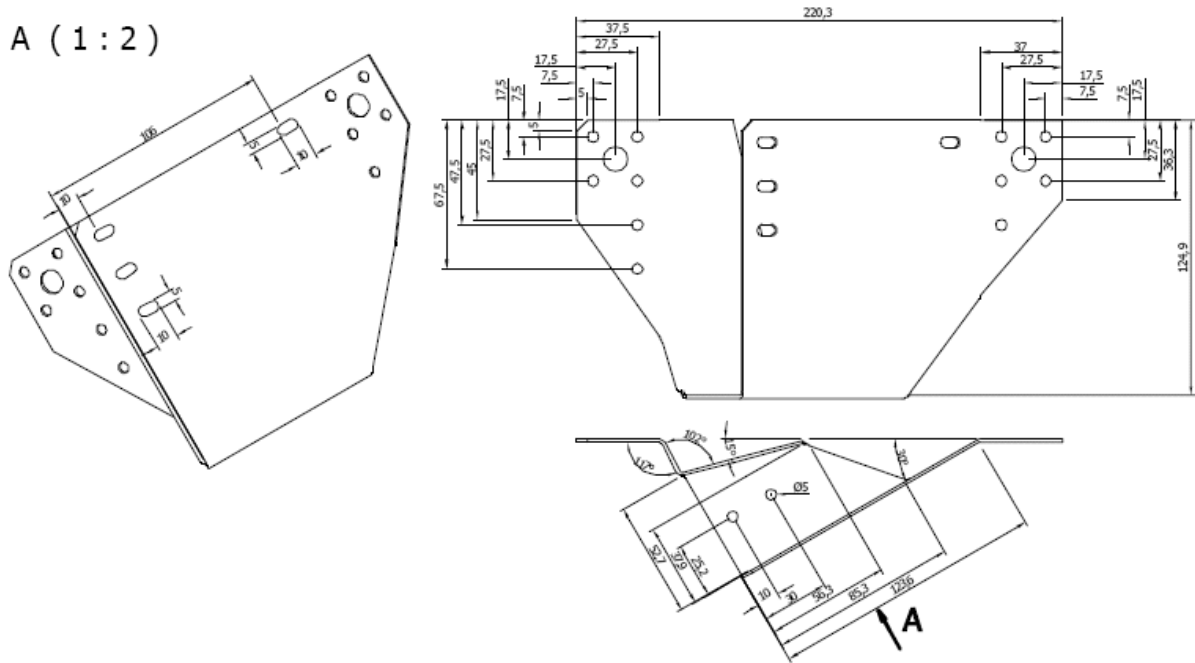

Figure 3: Dimensioned drawing of skewed hanger S1530G/38/1.5

S1530D/38/1.5

A (1 : 2)

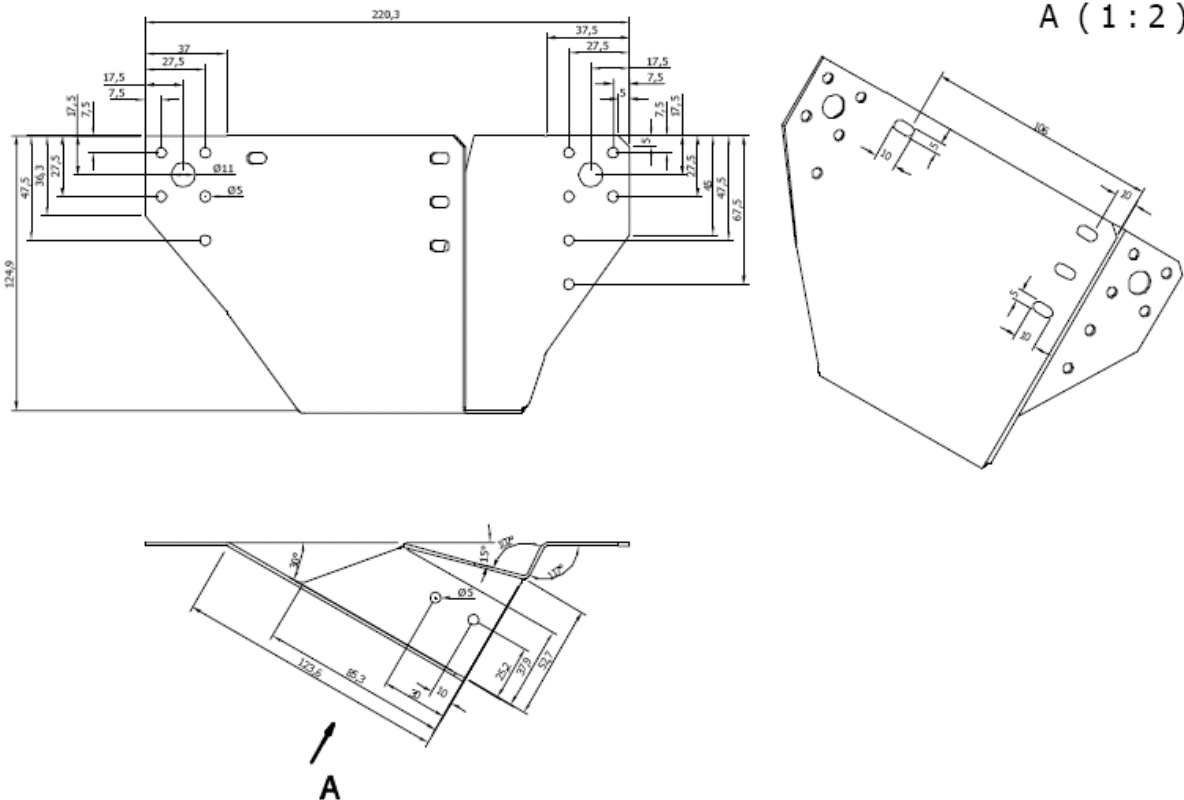
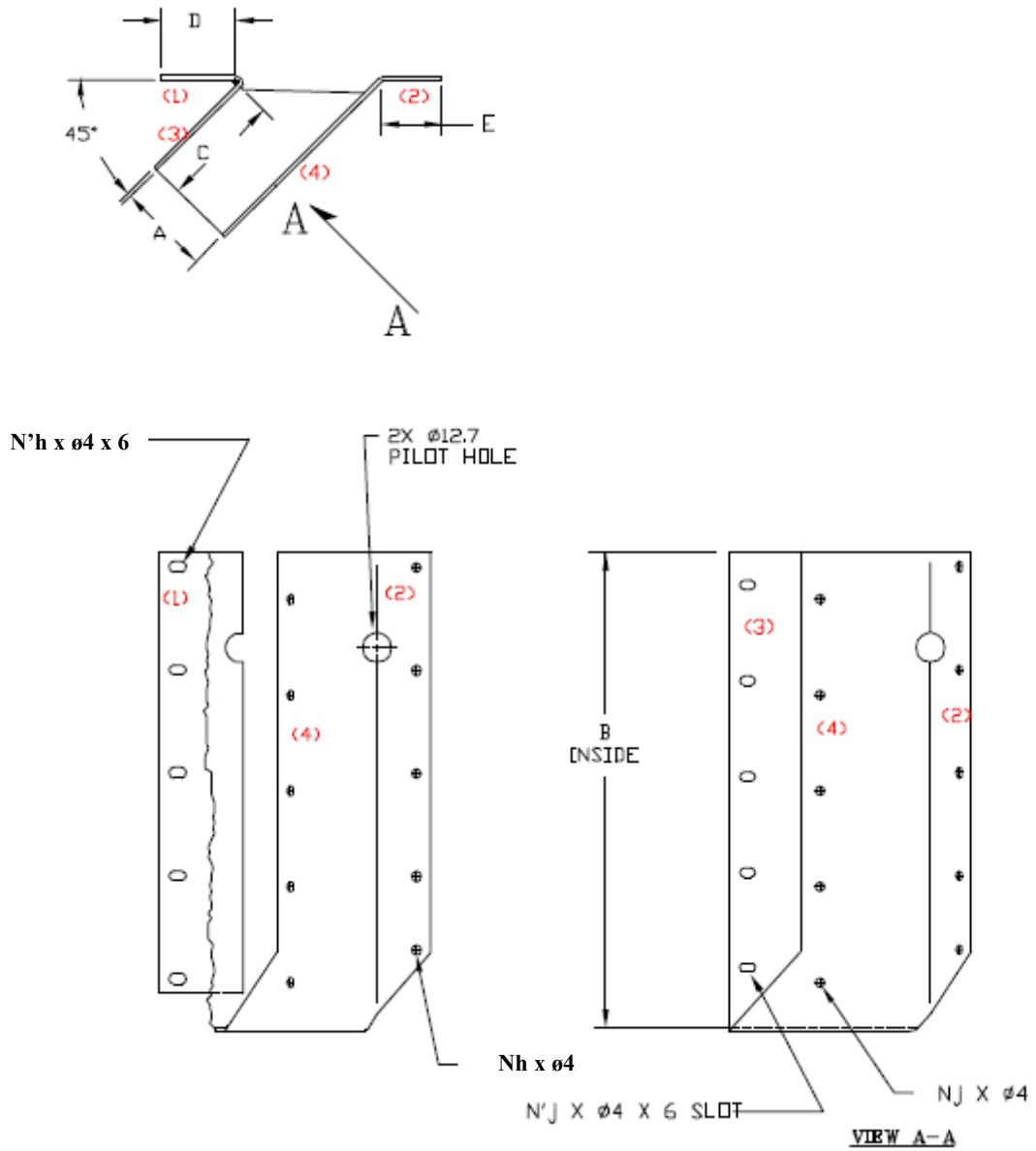

Figure 4: Dimensioned drawing of skewed hanger S1530D/38/1.5

**SUL/R hangers****SUL hangers**

Item	Dimensions (mm)						Hole Nail				Steel
	A	B	C	D	E	Thick	Nh header (open flange)	N'h header (closed flange)	Nj Joist (open side)	N'j Joist (closed side)	
SUL24	40	80	50	35	25	1,5	2 - $\emptyset 4$	2 - $\emptyset 4 \times 6$	2 - $\emptyset 4$	2 - $\emptyset 4 \times 6$	Pre-galvanised mild steel
SUL26	40	127	50	35	25	1,5	3 - $\emptyset 4$	3 - $\emptyset 4 \times 6$	3 - $\emptyset 4$	3 - $\emptyset 4 \times 6$	
SUL90/50	50	90	84	40	30	1,5	4 - $\emptyset 4$	4 - $\emptyset 4 \times 6$	2 - $\emptyset 4$	2 - $\emptyset 4 \times 6$	
SUL135/50	50	135	84	40	30	1,5	6 - $\emptyset 4$	6 - $\emptyset 4 \times 6$	3 - $\emptyset 4$	3 - $\emptyset 4 \times 6$	
SUL210/50	50	210	84	40	30	1,5	10 - $\emptyset 4$	10 - $\emptyset 4 \times 6$	4 - $\emptyset 4$	4 - $\emptyset 4 \times 6$	
SUL210	40	206	50	35	25	1,5	5 - $\emptyset 4$	5 - $\emptyset 4 \times 6$	5 - $\emptyset 4$	5 - $\emptyset 4 \times 6$	
SUL214	40	254	50	35	25	1,5	6 - $\emptyset 4$	6 - $\emptyset 4 \times 6$	6 - $\emptyset 4$	6 - $\emptyset 4 \times 6$	
SUL1.81/9	46	233	50	35	19	1,5	6 - $\emptyset 4$	6 - $\emptyset 4 \times 6$	4 - $\emptyset 4$	--	
SUL1.81/11	46	254	50	35	19	1,5	8 - $\emptyset 4$	8 - $\emptyset 4 \times 6$	5 - $\emptyset 4$	--	
SULI3510/12	58	228	73	44	43	1,5	7 - $\emptyset 4$	7 - $\emptyset 4 \times 6$	3 - $\emptyset 4$	3 - $\emptyset 4 \times 6$	
SULI3514/20	58	330	73	44	43	1,5	9 - $\emptyset 4$	9 - $\emptyset 4 \times 6$	4 - $\emptyset 4$	4 - $\emptyset 4 \times 6$	
SUL210-2	80	220	62	56	32	1,5	7 - $\emptyset 4$	7 - $\emptyset 4 \times 6$	3 - $\emptyset 4$	3 - $\emptyset 4 \times 6$	
SUL410	90	216	62	56	25	1,5	7 - $\emptyset 4$	7 - $\emptyset 4 \times 6$	3 - $\emptyset 4$	3 - $\emptyset 4 \times 6$	
SUL414	90	317	62	56	25	1,5	9 - $\emptyset 4$	9 - $\emptyset 4 \times 6$	4 - $\emptyset 4$	4 - $\emptyset 4 \times 6$	
SUL310	65	227	67	51	38	1,5	7 - $\emptyset 4$	7 - $\emptyset 4 \times 6$	3 - $\emptyset 4$	3 - $\emptyset 4 \times 6$	
SUL314	65	330	67	51	38	1,5	9 - $\emptyset 4$	9 - $\emptyset 4 \times 6$	4 - $\emptyset 4$	4 - $\emptyset 4 \times 6$	
SUL2.06/9	52	231	81	54	41	1,6	7 - $\emptyset 4$	7 - $\emptyset 4 \times 6$	4 - $\emptyset 4$	--	
SUL2.1/9	53	230	81	54	40	1,6	7 - $\emptyset 4$	7 - $\emptyset 4 \times 6$	4 - $\emptyset 4$	--	
SUL2.37/9	60	227	81	54	33	1,6	7 - $\emptyset 4$	7 - $\emptyset 4 \times 6$	4 - $\emptyset 4$	--	
SUL2.56/9	65	225	81	54	28	1,6	7 - $\emptyset 4$	7 - $\emptyset 4 \times 6$	4 - $\emptyset 4$	--	
SUL2.06/11	52	285	81	54	41	1,6	8 - $\emptyset 4$	8 - $\emptyset 4 \times 6$	4 - $\emptyset 4$	--	
SUL2.1/11	53	284	81	54	40	1,6	8 - $\emptyset 4$	8 - $\emptyset 4 \times 6$	4 - $\emptyset 4$	--	
SUL2.37/11	60	284	81	54	33	1,6	8 - $\emptyset 4$	8 - $\emptyset 4 \times 6$	4 - $\emptyset 4$	--	
SUL2.56/11	65	284	81	54	28	1,6	8 - $\emptyset 4$	8 - $\emptyset 4 \times 6$	4 - $\emptyset 4$	--	
SUL2.06/14	52	345	81	54	41	1,6	9 - $\emptyset 4$	9 - $\emptyset 4 \times 6$	4 - $\emptyset 4$	--	
SUL2.1/14	53	344	81	54	40	1,6	9 - $\emptyset 4$	9 - $\emptyset 4 \times 6$	4 - $\emptyset 4$	--	
SUL2.37/14	60	341	81	54	33	1,6	9 - $\emptyset 4$	9 - $\emptyset 4 \times 6$	4 - $\emptyset 4$	--	
SUL2.56/14	65	339	81	54	28	1,6	9 - $\emptyset 4$	9 - $\emptyset 4 \times 6$	4 - $\emptyset 4$	--	



- (1) left flange
- (2) right flange
- (3) closed side
- (4) open side

Figure 5: Dimensioned drawing of SUL hangers

## SUR hangers

Item	Dimensions (mm)						Hole Nail				Steel
	A	B	C	D	E	Thick	Nh header (open flange)	N'h header (closed flange)	Nj Joist (open side)	N'j Joist (closed side)	
SUR24	40	80	50	35	25	1,5	2 - $\emptyset 4$	2 - $\emptyset 4 \times 6$	2 - $\emptyset 4$	2 - $\emptyset 4 \times 6$	Pre-galvanised mild steel
SUR26	40	127	50	35	25	1,5	3 - $\emptyset 4$	3 - $\emptyset 4 \times 6$	3 - $\emptyset 4$	3 - $\emptyset 4 \times 6$	
SUR90/50	50	90	84	40	30	1,5	4 - $\emptyset 4$	4 - $\emptyset 4 \times 6$	2 - $\emptyset 4$	2 - $\emptyset 4 \times 6$	
SUR135/50	50	135	84	40	30	1,5	6 - $\emptyset 4$	6 - $\emptyset 4 \times 6$	3 - $\emptyset 4$	3 - $\emptyset 4 \times 6$	
SUR210/50	50	210	84	40	30	1,5	10 - $\emptyset 4$	10 - $\emptyset 4 \times 6$	4 - $\emptyset 4$	4 - $\emptyset 4 \times 6$	
SUR210	40	206	50	35	25	1,5	5 - $\emptyset 4$	5 - $\emptyset 4 \times 6$	5 - $\emptyset 4$	5 - $\emptyset 4 \times 6$	
SUR214	40	254	50	35	25	1,5	6 - $\emptyset 4$	6 - $\emptyset 4 \times 6$	6 - $\emptyset 4$	6 - $\emptyset 4 \times 6$	
SUR1.81/9	46	233	50	35	19	1,5	6 - $\emptyset 4$	6 - $\emptyset 4 \times 6$	4 - $\emptyset 4$	--	
SUR.1.81/11	46	254	50	35	19	1,5	8 - $\emptyset 4$	8 - $\emptyset 4 \times 6$	5 - $\emptyset 4$	--	
SUR13510/12	58	228	73	44	43	1,5	7 - $\emptyset 4$	7 - $\emptyset 4 \times 6$	3 - $\emptyset 4$	3 - $\emptyset 4 \times 6$	
SUR13514/20	58	330	73	44	43	1,5	9 - $\emptyset 4$	9 - $\emptyset 4 \times 6$	4 - $\emptyset 4$	4 - $\emptyset 4 \times 6$	
SUR210-2	80	220	62	56	32	1,5	7 - $\emptyset 4$	7 - $\emptyset 4 \times 6$	3 - $\emptyset 4$	3 - $\emptyset 4 \times 6$	
SUR410	90	216	62	56	25	1,5	7 - $\emptyset 4$	7 - $\emptyset 4 \times 6$	3 - $\emptyset 4$	3 - $\emptyset 4 \times 6$	
SUR414	90	317	62	56	25	1,5	9 - $\emptyset 4$	9 - $\emptyset 4 \times 6$	4 - $\emptyset 4$	4 - $\emptyset 4 \times 6$	
SUR310	65	227	67	51	38	1,5	7 - $\emptyset 4$	7 - $\emptyset 4 \times 6$	3 - $\emptyset 4$	3 - $\emptyset 4 \times 6$	
SUR314	65	330	67	51	38	1,5	9 - $\emptyset 4$	9 - $\emptyset 4 \times 6$	4 - $\emptyset 4$	4 - $\emptyset 4 \times 6$	
SUR2.06/9	52	231	81	54	41	1,6	7 - $\emptyset 4$	7 - $\emptyset 4 \times 6$	4 - $\emptyset 4$	--	
SUR2.1/9	53	230	81	54	40	1,6	7 - $\emptyset 4$	7 - $\emptyset 4 \times 6$	4 - $\emptyset 4$	--	
SUR2.37/9	60	227	81	54	33	1,6	7 - $\emptyset 4$	7 - $\emptyset 4 \times 6$	4 - $\emptyset 4$	--	
SUR2.56/9	65	225	81	54	28	1,6	7 - $\emptyset 4$	7 - $\emptyset 4 \times 6$	4 - $\emptyset 4$	--	
SUR2.06/11	52	285	81	54	41	1,6	8 - $\emptyset 4$	8 - $\emptyset 4 \times 6$	4 - $\emptyset 4$	--	
SUR2.1/11	53	284	81	54	40	1,6	8 - $\emptyset 4$	8 - $\emptyset 4 \times 6$	4 - $\emptyset 4$	--	
SUR2.37/11	60	284	81	54	33	1,6	8 - $\emptyset 4$	8 - $\emptyset 4 \times 6$	4 - $\emptyset 4$	--	
SUR2.56/11	65	284	81	54	28	1,6	8 - $\emptyset 4$	8 - $\emptyset 4 \times 6$	4 - $\emptyset 4$	--	
SUR2.06/14	52	345	81	54	41	1,6	9 - $\emptyset 4$	9 - $\emptyset 4 \times 6$	4 - $\emptyset 4$	--	
SUR2.1/14	53	344	81	54	40	1,6	9 - $\emptyset 4$	9 - $\emptyset 4 \times 6$	4 - $\emptyset 4$	--	
SUR2.37/14	60	341	81	54	33	1,6	9 - $\emptyset 4$	9 - $\emptyset 4 \times 6$	4 - $\emptyset 4$	--	
SUR2.56/14	65	339	81	54	28	1,6	9 - $\emptyset 4$	9 - $\emptyset 4 \times 6$	4 - $\emptyset 4$	--	

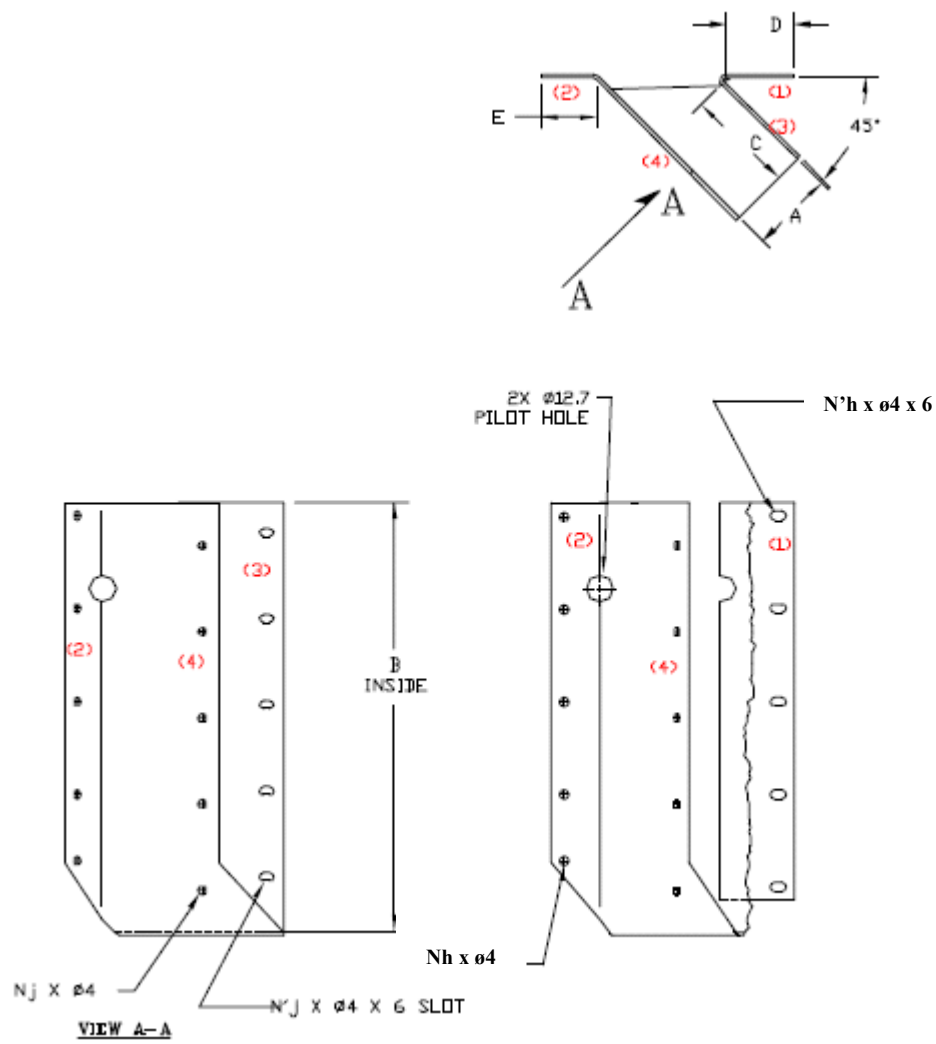

- (1) left flange
- (2) right flange
- (3) closed side
- (4) open side

Figure 6: Dimensioned drawing of SUR hangers

## HSUR/L hangers

### HSUR hangers

Item	Dimensions (mm)						Hole Nail				Steel
	A	B	C	D	E	Thick	Nh header (open flange)	N'h header (closed flange)	Nj Joist (open side)	N'j Joist (closed side)	
HSUR26-2	80	125	62	56	32	2	6 - $\phi 4$	6 - $\phi 4 \times 6$	2 - $\phi 4$	2 - $\phi 4 \times 6$	Pre-galvanised mild steel
HSUR410	90	216	62	56	25	2	10 - $\phi 4$	10 - $\phi 4 \times 6$	3 - $\phi 4$	3 - $\phi 4 \times 6$	
HSUR414	90	317	62	56	25	2	13 - $\phi 4$	13 - $\phi 4 \times 6$	4 - $\phi 4$	4 - $\phi 4 \times 6$	

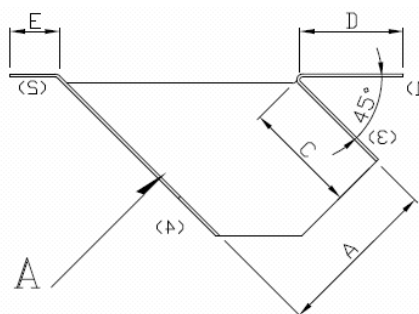

View A

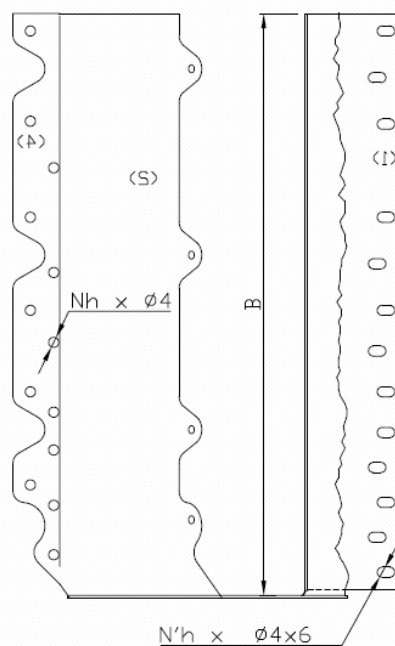
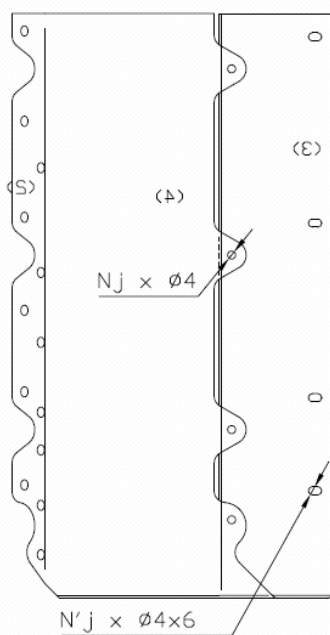

- (1) left flange
- (2) right flange
- (3) closed side
- (4) open side

Figure 7: Dimensioned drawing of HSUR hangers

### HSUL hangers

Item	Dimensions (mm)						Hole Nail				Steel
	A	B	C	D	E	Thick	Nh header (open flange)	N'h header (closed flange)	Nj Joist (open side)	N'j Joist (closed side)	
HSUL26-2	80	125	62	56	32	2	6 - $\varnothing 4$	6 - $\varnothing 4 \times 6$	2 - $\varnothing 4$	2 - $\varnothing 4 \times 6$	Pre-galvanised mild steel
HSUL410	90	216	62	56	25	2	10 - $\varnothing 4$	10 - $\varnothing 4 \times 6$	3 - $\varnothing 4$	3 - $\varnothing 4 \times 6$	
HSUL414	90	317	62	56	25	2	13 - $\varnothing 4$	13 - $\varnothing 4 \times 6$	4 - $\varnothing 4$	4 - $\varnothing 4 \times 6$	

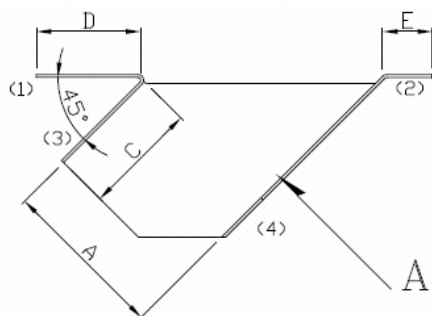

View A

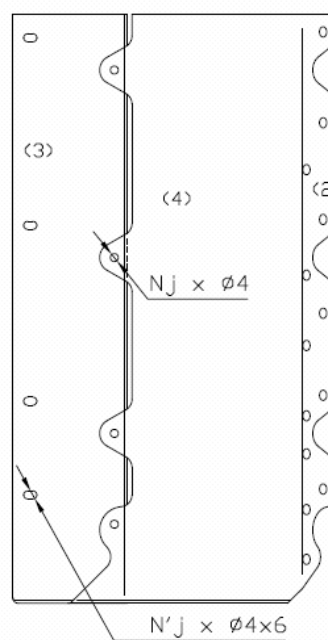
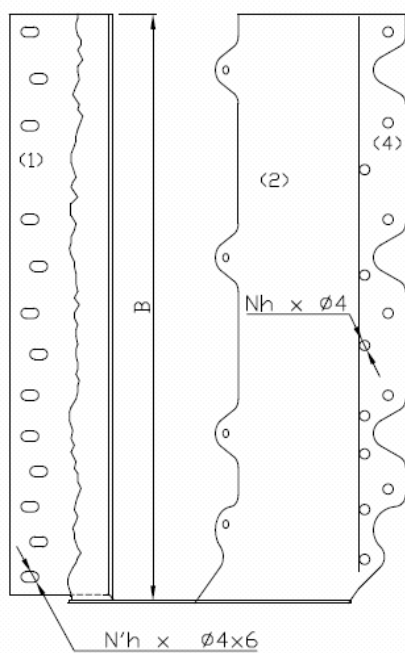

- (1) left flange
- (2) right flange
- (3) closed side
- (4) open side

Figure 8: Dimensioned drawing of HSUR=L hangers

## Annex A Product details and definitions

### Part 2: Fastener specifications

Table 1: Nail and screw specification for timber to timber connections with fasteners in accordance with ETA-04/0013

Nail and screw type	Nail and screw size (mm)		Finish
	Diameter	Length	
According to ETA-04/0013			
Connector nail	4,0	35	Electroplated zinc
Connector nail	4,0	40	Electroplated zinc
Connector nail	4,0	50	Electroplated zinc
Connector nail	4,0	60	Electroplated zinc
Connector screw	5,0	35	Electroplated zinc
Connector screw	5,0	50	Electroplated zinc
Connector nail	4,2	35	Electroplated zinc
Connector nail	4,2	50	Electroplated zinc

Table 2: Nail specifications for timber to timber connections with nails in accordance with prEN 14592

Nail and screw type	Nail and screw size (mm)		Finish
	Diameter	Length	
Smooth Shank nail	4.0	90	Galvanized
Square Twist nail	3.75	30	Galvanized

Table 3: Bolt specification

Bolt type	Bolt size (mm)		Capacities
	Diameter	Length	
		-	For relevant joist hangers see the assumed characteristic capacities of the bolt connection and compare with the specification of the manufacturer
Bolt M12 Quality 4.6	12	-	

### Annex B Characteristic capacities

#### Characteristic capacities of the joist hanger connections with nails or screws only.

The downward and the upward directed forces are assumed to act in the middle of the joist.

- There shall be nails or screws in the holes as described in the tables of this annex. Typically there shall be nails in all holes.
- The type and size of the fasteners shall be those stated in the tables.
- Threaded nails are Simpson connector nails  
Smooth nails and square twist nails are in accordance with prEN 14592
- The thickness of the joist shall be at least  $B - 3$  mm, where B is the width of the joist hanger.

The characteristic load-carrying capacities of the skew joist hanger connections for timber to timber connections are stated in the following tables.

For timber to timber connections the following tables state the number of nails and their sizes.

For joist hanger type S45 it is possible to fasten the joist hanger to a member made from concrete or similar material by using 12 mm anchor bolts. This is not an option for the other joist hanger types.

The following fasteners are used for connections to wood:

Nail size and type	Hanger type			
	S45	S1530	HSUR/HSUL	SUR/SUL
4,0 x 35 ARS	yes	yes		
4,0 x 50 ARS	yes	yes		
4,0 x 60 ARS*			yes	yes
4,2 x 35 ARS*	yes	yes		
4,2 x 50 ARS*	yes	yes		
3,75x30 ST	no	no	yes	yes
4,0x 90 SS			yes	yes
5,0x35 S*	yes	yes		
5,0x50 S*	yes	yes		

ARS = Annular Ring Shank ST = Square Twist SS = Smooth Shank S = Screw

\*4,2 mm ARS and 5,0 mm S by the substitution rule that a nail can be substituted by a stronger nail or screw

**B.1 Joist hanger type S45**

For timber to concrete connections the number and size of the nails in the joist shall be those stated in the table. The anchor bolts into the concrete or similar type of structural member shall have a characteristic lateral capacity as stated in the table. The quality of the bolt material shall be at least 4.6.

Table B.1.1. Characteristic load-carrying capacities of type S45, number and size of Simpson connector nails, 12 mm bolts 4.6.

Joist hanger size	Timber to timber connections Connector nails, Nail types and sizes		$R_k$		Joist hanger on a concrete wall		
	Number of nails and size				$R_k$		Provided minimum charac. Lateral capacity kN
	Header	Joist	Down kN	Up kN	Down kN	Up kN	
S45 250/38	2x8x4,0x50	2x8x4,0x35	4,3	0	0	0	
S45 320/38	2x9x4,0x50	2x5x4,0x35	14,0	3,2	14,0	3,2	7,4
S45 320/64	2x9x4,0x50	2x5x4,0x35	14,0	3,2	14,0	3,2	7,4
S45 380/76	2x13x4,0x50	2x6x4,0x50	16,2	4,2	16,2	4,2	8,8
S45 440/80	2x14x4,0x50	2x7x4,0x50	18,5	5,6	18,5	5,6	9,3
S45 500/100	2x17x4,0x50	2x9x4,0x50	23,4	8,3	23,0	8,3	12,0

Instead of the connector nails mentioned in table B.1.1 the connector nails can be substituted by the nails or screws mentioned in table B.1.2. These fasteners have larger characteristic capacities than the mentioned connector nails according to the ETA 04/0013.

Table B.1.2. Substitution possibilities of fasteners. The connector nails may be substituted by the connector nails with a larger diameter or by the connector screws.

Connector nails which may be substituted by the other fasteners	Other connector nails	Other connector screws
4,0x35 mm	4,2x35 mm	5,0x35 mm
4,0x50 mm	4,2x50 mm	5,0x40 mm

**B.2 Joist hanger Type SUL / SUR**

For timber to timber connections the number and size of the nails in the joist and the header shall be those stated in the table.

Table B 2.1. Characteristic load-carrying capacities of type SUL / SUR, type, number and size of SS Smooth Shank round nails and ST Square Twist nails.

Joist Hanger Type	Header Nail types and sizes		$R_k$	
	SS 4,0 x 90 Number of nails	ST 3,75 X 30	Down kN	Up kN
<b>SUL / SUR</b>				
210	2x5	2x5	11,38	10,83
214	2x6	2x6	13,24	11,49
1.81/9	2x6	4	4,19	0
1.81/11	2x8	4	4,28	0
3510/12	2x7	2x3	14,59	5,59
3514/20	2x9	2x4	20,02	9,35
310	2x7	2x3	14,48	5,78
314	2x9	2x4	19,86	9,57
210-2	2x7	2x3	13,18	5,69
410	2x7	2x3	14,14	5,34
414	2x9	2x4	18,80	8,96
24	2x2	2x2	3,48	2,75
26	2x3	2x3	6,13	8,38
90/50	2x4	2x2	4,55	1,46
135/50	2x6	2x3	8,44	2,86
210/50	2x10	2x4	15,66	6,11
2.06/9	2x7	4	4,55	0
2.1/9	2x7	4	4,64	0
2.37/9	2x7	4	4,88	0
2.56/9	2x7	4	5,08	0
2.06/11	2x8	4	4,66	0
2.1/11	2x8	4	4,75	0
2.37/11	2x8	4	5,00	0
2.56/11	2x8	4	5,21	0
2.06/14	2x9	6	6,48	0
2.1/14	2x9	6	6,55	0
2.37/14	2x9	6	6,97	0
2.56/14	2x9	6	7,18	0

Instead of the connector nails mentioned in table B.2.1 the connector nails can be substituted by the nails or screws mentioned in table B.2.2. These fasteners have larger characteristic capacities than the mentioned connector nails according to the ETA 04/0013.

Table B.2.2. Substitution possibilities of fasteners. The smooth round nails may be substituted by the connector nail.

Smooth round nail which may be substituted by the other connector nail	Other connector nails
4,0x90 mm	4,0x60 mm

### B.3 Joist hanger Type HSUL / HSUR

For timber to timber connections the number and size of the nails in the joist and the header shall be those stated in the table.

Table B 3.1. Characteristic load-carrying capacities of type SUL / SUR, type, number and size of SS Smooth Shank round nails and ST Square Twist nails.

Joist Hanger Type	Header Nail types and sizes		Joist		$R_k$
	SS	ST	Down	Up	
	4,0 x 90	3,75 X 30	kN	kN	
	Number of nails				
<b>HSUL / HSUR</b>					
HSUL26-2	2x6	2x2	8,57	2,40	
HSUL410	2x10	2x3	17,35	5,57	
HSUL414	2x13	2x4	29,78	9,23	

Instead of the connector nails mentioned in table B.3.1 the connector nails can be substituted by the nails or screws mentioned in table B.3.2. These fasteners have larger characteristic capacities than the mentioned connector nails according to the ETA 04/0013.

Table B.3.2. Substitution possibilities of fasteners. The smooth round nails may be substituted by the connector nail.

Smooth round nail which may be substituted by the other connector nail	Other connector nails
4,0x90 mm	4,0x60 mm

**B.4 Joist hanger Type S1530**

For timber to timber connections the number and size of the nails in the joist and the header shall be those stated in the table. There shall be nails in all holes. In the bottom plate there shall be 2 nails from below.

The width of the joist shall be 38 mm.

Table B.4.1. Characteristic load-carrying capacities of type S1530, number and size of Simpson connector nails and depending on the angle between the header and the joist, which can be either 15° or 30°.

Type / angle	Nails in joist	Nails in header	Characteristic Load-carrying capacity.	
	4,0x35	4,0x50	Down	Up
	Number	Number	kN	kN
S1530/15	3 + 2	5 + 6	1,9	1,2
S1530/30	3 + 2	5 + 6	4,3	1,2

Instead of the connector nails mentioned in table B.4.1 the connector nails can be substituted by the nails or screws mentioned in table B.4.2. These fasteners have larger characteristic capacities than the mentioned connector nails according to the ETA 04/0013.

Table B.4.2. Substitution possibilities of fasteners. The connector nails may be substituted by the connector nails with a larger diameter or by the connector screws.

Connector nails which may be substituted by the other fasteners	Other connector nails	Other connector screws
4,0x35 mm	4,2x35 mm	5,0x35 mm
4,0x50 mm	4,2x50 mm	5,0x40 mm